

ReefATO+

User Manual

ENG

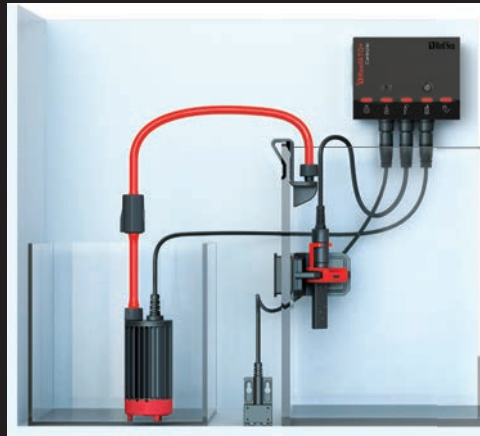

ReefATO+

Smart ATO – Temperature Sensor – Leak Detector

User Manual

 Red Sea

Contents

Introduction	6
Safety	7
Components of the ReefATO+ system	8
Guide to the ReefATO+ Controller	9
How the ReefATO+ Auto-Fill system works	11
Introduction to the ReefBeat app	12
Installing the ReefATO+ system	12
Setting up the ReefATO+	16
Troubleshooting	21
Warranty	22

Introduction

Congratulations on your purchase of Red Sea's 3-in-1 ReefATO+ smart Reef Aquarium ATO system, plus temperature monitor and leak detector.

The ReefATO+ is designed to maintain a stable salinity and water volume in a reef aquarium by automatically replenishing the water lost due to evaporation.

The ReefATO+ consists of a slim-line, multi-input, solid-state water level sensor, bespoke DC pump, wi-fi connected controller and a complete set of accessories required to install the system. In addition, the ReefATO+ provides two other critical aquarium health indicators; a fully featured on-line digital temperature monitor that is embedded in the level sensor and an external leak detector.

The ReefATO+ is part of Red Sea's suite of smart devices that are operated via Wi-Fi by Red Sea's ReefBeat® App, which needs to be installed on a smart mobile device with internet connectivity.

Welcome to Red Sea's smart reef-keeping.

The Red Sea Team

Safety

PLEASE READ AND FOLLOW ALL SAFETY INSTRUCTIONS

THIS DEVICE IS INTENDED FOR INDOOR USE ONLY.

DANGER: To avoid possible electric shock, special care should be taken when handling a wet aquarium. For each of the following situations, do not attempt repairs yourself; return the appliance to an authorized service facility for service or discard the appliance.

WARNING: To guard against injury, basic safety precautions should be observed, including the following:

Do not operate any appliance if it has a damaged cord or plug, if it is malfunctioning, or if it is dropped or damaged in any manner.

This appliance can be used by children aged from 8 years and above and persons with reduced physical, sensory, or mental capabilities or lack of experience and knowledge if they have been given supervision or instruction concerning use of the appliance in a safe way and understand the hazards involved. Children shall not play with the appliance. Cleaning and user maintenance shall not be made by children without supervision.

The appliance is only to be used with the power supply unit provided with the appliance. Close supervision is necessary when any appliance is used by or near children.

To avoid injury, do not contact moving parts.

Always unplug an appliance

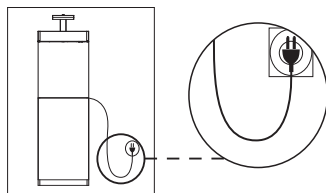

Figure 1: Drip Loop

from an outlet when not in use, before putting on or taking off parts, and before cleaning. Never pull the cord itself to remove the plug from the outlet. Grasp the plug and pull to disconnect.

Do not use an appliance for anything other than its intended use. The use of attachments not recommended or sold by the appliance manufacturer may cause unsafe conditions.

Do not install or store the appliance where it will be exposed to the weather or to temperatures below freezing point.

Make sure an appliance is securely installed before operating it.

Read and observe all the important notices on the appliance.

Note: A cord rated for less amperes or watts than the appliance rating may overheat. Care should be taken to arrange the cord so that it cannot be tripped over or pulled accidentally.

Do not use if cord is damaged. In case of need, do not attempt to replace or repair yourself; return the appliance to an authorized service facility for service or discard the appliance.

In case of need, do not attempt to replace yourself; return the appliance to an authorized service facility for service or discard the appliance.

Components of the ReefATO+ system

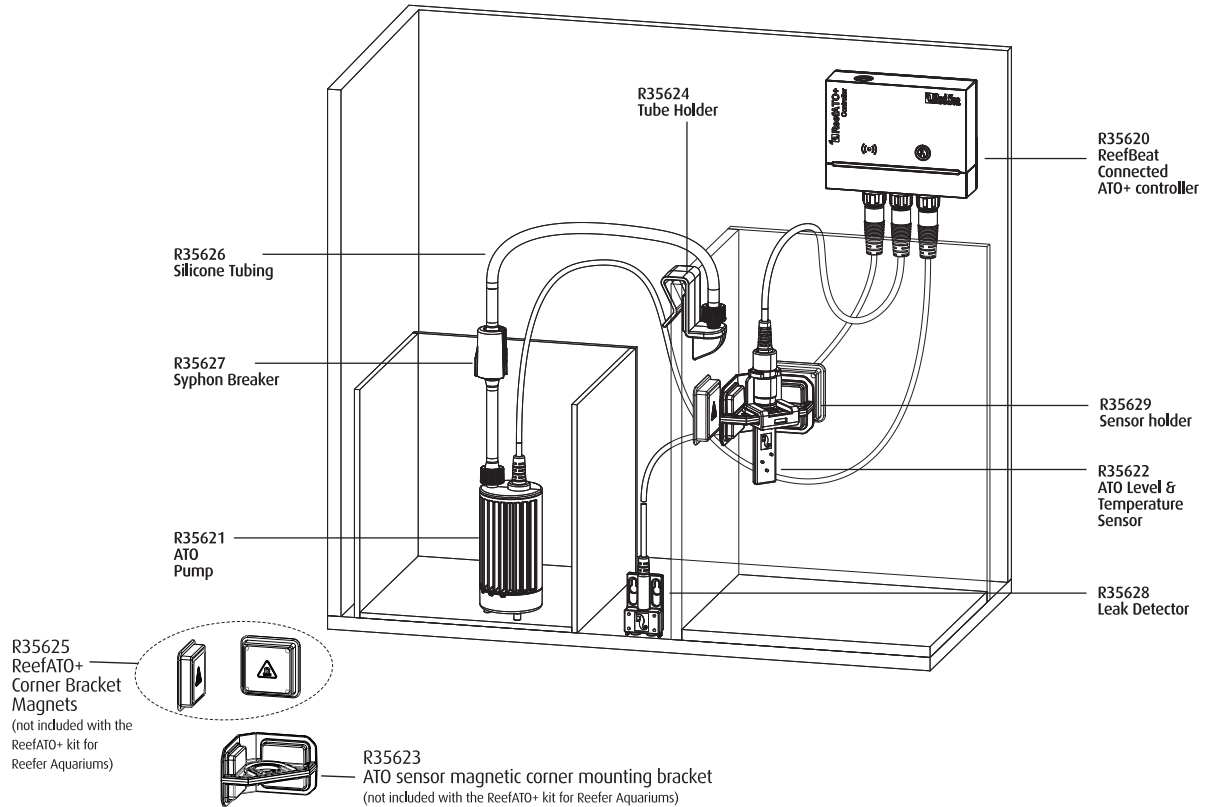

Guide to the ReefATO+ Controller

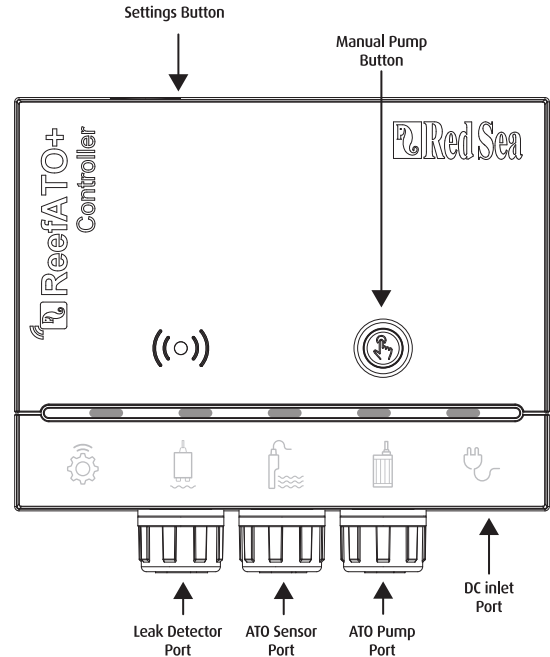
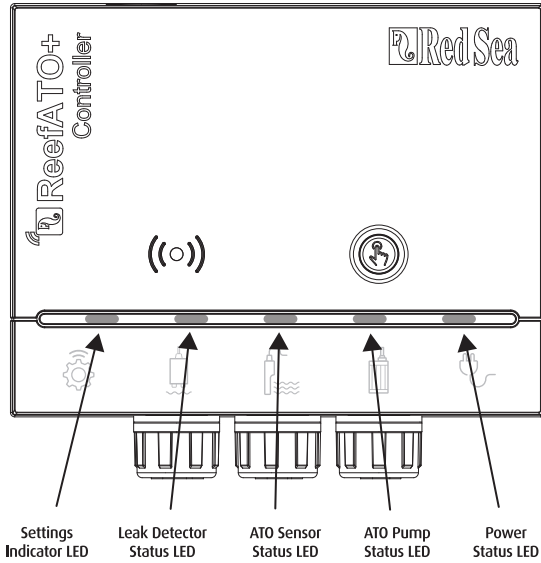

LED Indicators

Settings LED Indicator:

- Solid Red light – Controller is connected to the home-network.
- Blinking Red light – Controller is in Wi-Fi Access Point (AP) mode (can be discovered by Wi-Fi devices).
- Rapid Blinking Red light – Controller cannot access the home-network (network name and/or password are incorrect or known network has become unavailable)
- No Red light – Controller Wi-Fi is off.
- Double blink – indicates change of status / end of process.

Leak Detector Status LED Indicator:

- Solid Red light –Leak detection is enabled
- No Red light – Leak detection is disabled
- Blinking Red light – Leak has been detected and Auto-Fill has been disabled

ATO Sensor Status LED Indicator:

- Solid Red light –Auto-Fill is enabled
- No Red light –Auto-Fill is disabled
- Blinking Red light – ATO Sensor is missing

Pump Status LED Indicator:

- Solid Red light – Pump is on.
- No Red light – Pump is off.
- Blinking Red light – Pump malfunction (missing, stalled, or running dry)

Power LED Indicator:

- Solid Red light –PSU is attached.
- No Red light –PSU is not attached.

Settings Button – Function

If settings indicator LED is off (ReefATO+ Controller Wi-Fi is off): Pressing button for 5 seconds (until double blink) activates Wi-Fi AP mode.

If settings indicator LED is blinking (ReefATO+ Controller Wi-Fi is in AP mode): Pressing button for 5 seconds (until double blink) switches Wi-Fi off.

If indicator LED is on (ReefATO+ Controller Wi-Fi is connected to a Wi-Fi network): Pressing button for 5 seconds (until double blink) disconnects the ReefATO+ from the network and switches it to Wi-Fi AP mode. (Note: before disconnecting a ReefATO+ from a network, delete it from the ReefBeat App via the Device Manager.) Note: All settings are retained and can be restored when reconnecting to the ReefBeat.

Reboot: Pressing and releasing the button for less than 2 seconds will cause the unit to shut down and restart. User settings are not affected.

Clear Settings: Pressing the button for 15 seconds (until double blink) deletes all user settings and switches the Wi-Fi to AP mode. Complete the reset process by disconnecting and reconnecting the DC power.

Manual Pump Button - Function

Pressing on the manual pump button will operate the pump for as long as it is pressed. The pump status LED will be on while the pump is running. In the event that the Auto-fill has been automatically disabled by the controller (such as if the RO reservoir has run out of water) a short press on pump button will reinstate the Auto-fill function.

How the ReefATO+ Auto-Fill system works

During regular operation when Auto-Fill is enabled, the water level will be maintained within the 3mm / 1/8" band between the pump-on and pump-off probes of the ATO sensor. As soon as the water level drops to the bottom of the "pump-on" probe, the ATO pump will automatically switch on and will continue pumping water from the RO reservoir until the water level rises to the "pump-off" probe, at which time the pump will automatically switch off.

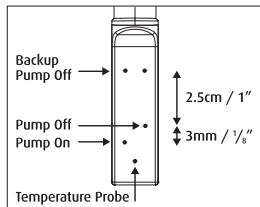

In the unlikely event that the "pump-off" probe does not sense the rise of the water level there are backup "pump-off" probes located approx. 2.5cm / 1" above the regular "pump-off" probe.

As an additional safety feature, there is an automatic pump timeout feature that will switch the pump off if it runs for significantly longer than the normal fill time for your system.

The Auto-Fill will automatically switch off if any of the following situations occur:

- Pump is missing, over-run timeout, running dry (empty reservoir) or blocked.
- Level/temp sensor is missing.
- Leak detector detects a leak.

The full array of titanium probes also provides an on-line indication if the water level is above, below or at the desired level.

ReefATO+ Temperature monitor

The ATO level sensor includes an accurate digital thermometer that is connected to the lower titanium probe enabling a quick response to temperature changes. The thermometer has been pre-calibrated to an accuracy of 0.1 degrees to ensure a reliable absolute temperature reading at all times. The ReefBeat App allows you to set a desired range and a wider acceptable range of temperatures for triggering notifications and presents a full log for analysis. The ReefBeat also allows you to offset the temperature reading to synchronize it with other temperature monitors you may have on your system.

ReefATO+ Leak Detector

The ReefATO+ leak detector is highly sensitive and will detect the full range of waters from RODI to seawater. When a leak is detected the ATO Auto-fill is immediately disabled including switching off the ATO pump if it was running. To avoid false alarms, the system waits a few seconds to confirm that the leak persists and then sounds an audible alarm as well as sending a notification to your mobile device. The ReefBeat App allows you to connect the leak detector to the Emergency Quick-action function in order to automatically shut down other ReefBeat devices such as return pumps in case a leak is detected.

Introduction to the ReefBeat app

All Red Sea's connected devices are operated via the ReefBeat app which must be installed on a mobile device with an internet connection (including tablets). See the full list of supported mobile devices on our website.

Through your personal user account on the cloud, ReefBeat enables you to set up and manage any number of aquariums and add multiple devices to each of them.

For full functionality, the controller must have a permanent connection to the internet through your home Wi-Fi network. In this mode of operation, you will be able to see the current status of your ReefATO+, change the settings or receive notifications on your mobile whenever you have access to the internet.

The ReefBeat homepage will show you the current status of all your connected devices, and links you directly to the Settings page of each unit.

You can install ReefBeat on multiple mobile devices by entering the same user account details. All mobile devices will have the same rights for operating and changing all the settings. You should keep this in mind before giving your user details to any 3rd party.

If you do not have a home network or your home network does not have an active internet connection, you can connect and control your ReefATO+ in Offline or Direct Mode. However, certain functionality such as remote access, multiple mobile devices or status notifications will not be available.

ReefBeat is constantly under development. For the most up to date operation instructions, view or download the latest user guide from the Red Sea website at www.redseafish.com

If this is your first Red Sea connected device, it is recommended that you complete the physical installation of your ReefATO+ before installing the ReefBeat app.

Installing the ReefATO+ system

Locate the ReefATO+ controller in a convenient position and attach the mounting bracket using screws or the adhesive tape provided. The controller is designed to operate in a humid environment but it is not waterproof. Please take the appropriate precautions in choosing its location and whenever removing the controller from the mounting bracket.

When selecting the exact location for the controller consider the following:

The power supply unit that is plugged into the rear of the controller and the AC outlet has a 2m / 6.5' cable.

The ATO pump that will be located in the RO reservoir has a 3m / 10' cable that needs to be connected to the bottom of the controller.

The ATO sensor that should be located in the return pump chamber of your sump has a 3m cable that needs to be connected to the bottom of the controller.

The Leak detector should be located at a convenient point around the outside of the aquarium and has a 3m / 10' cable that needs to be connected to the bottom of the controller.

The ATO sensor should be located in a corner of the return pump chamber so that the desired water level is approximately between the "pump on" and "pump off" pins. The water level will automatically adjust to this level once it begins regular operation.

For Red Sea aquariums click the sensor holder onto the glass triangle located in the return pump chamber. For older systems that have the gravity fed float valve, remove the valve by unscrewing the nut that holds it in place and then click the sensor holder onto the glass triangle.

For non-Red Sea sumps, attach the sensor holder to the magnetic corner bracket that will ensure that the sensor is always vertical. The external magnets are waterproof and can be mounted on internal walls of the sump. Note: the magnets are very strong and care needs to be taken when using them.

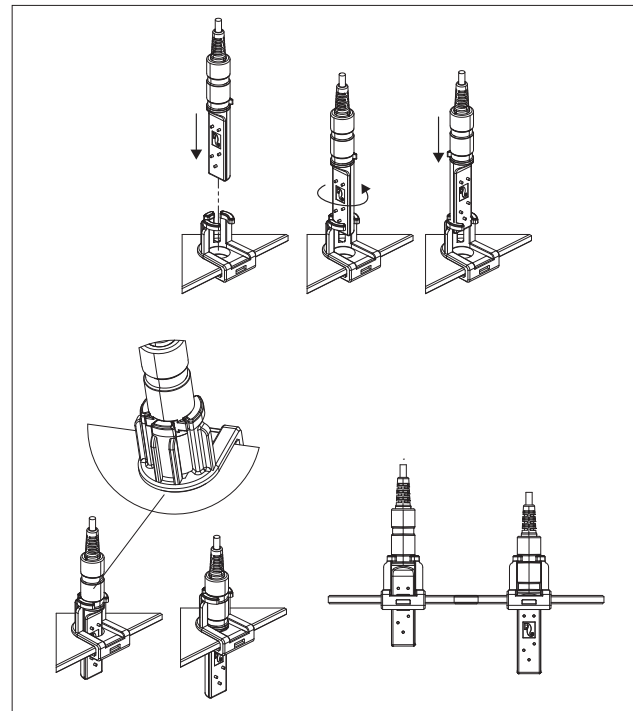
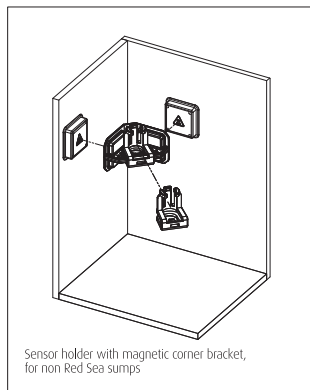
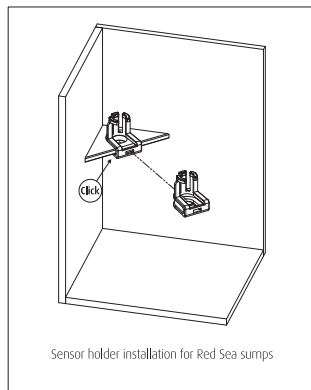

Slide the sensor into the sensor holder and click into the higher or lower position as suitable for your system. Thread the cable of the sensor through the cabinet and connect to the sensor port of the controller.

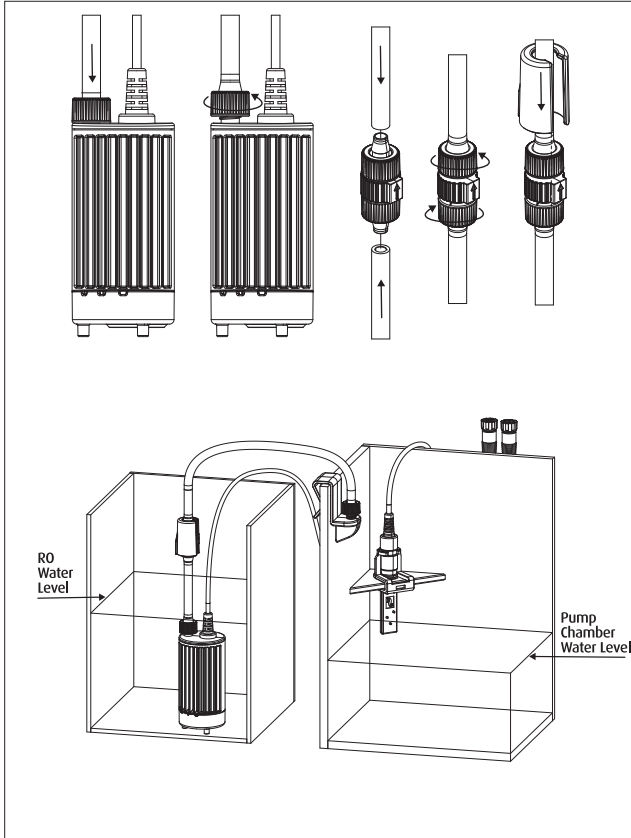

Using the silicone tube provided, connect the water outlet of the ATO pump to the tube holder that should be attached to the top rim of the sump chamber where the sensor is located. To ensure a secure connection make sure that the tube is cut straight and at 90 degrees to the tube, push the tube over the hose-barb until it is touching the securing nut and screw the nut counter-clockwise over the tube. The outlet of the holder should be above the highest expected water level in the sump and preferably not directly above the sensor. If the maximum water level in the RO reservoir can be higher than the tube holder, install the syphon breaker on the silicone tube so that it is below the rim of the RO reservoir, but will always be above the water level. Note: water will trickle from the syphon breaker back into the RO reservoir whenever the pump is working. Secure the tube to each of the components using the lock nuts provided and place the pump into the RO reservoir. Make a note of the approximate length of tube used to connect the pump to the tube holder and the vertical height from the bottom of the pump to the outlet of the tube holder as you will need this information for the App.

For quiet operation and to utilize almost all of the available water, locate the pump so that it is vertical and not touching the reservoir walls. Thread the power cable of the pump through the cabinet and connect to the pump port of the controller.

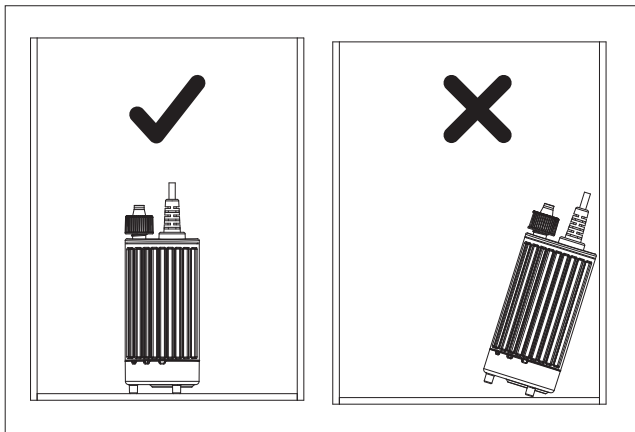

Locate the leak detector at a convenient point around the outside of the aquarium and secure in position with the self-adhesive Velcro pads, or with screws. Thread the cable of the leak detector through the cabinet and connect to the leak detector port of the controller. Installation of the leak detector is optional and will not affect the operation of the ATO system if it is not installed.

When all preparations are complete, connect the power supply to the DC jack on the rear of the controller and plug it into the AC wall outlet. The power indicator LED will turn on to show that the power supply is connected, pressing the manual button on the front of the controller will operate the pump, however, the ATO system will not work automatically until the controller has been onboarded to the ReefBeat App and the Auto-fill enabled.

Follow the instruction below to onboard the ReefATO+ controller to the ReefBeat App.

Connection and initial Setup

Download and install the ReefBeat-App from the app Store or Google Play as appropriate for your Mobile Device. (In countries without access to Google Play, an APK file and installation instructions can be downloaded from Red Sea's website.)

After installing ReefBeat, you will be guided through the set-up of your ReefBeat user account and aquariums, and then you can start adding your Red Sea connected devices. All your user account details can be edited, but only when your mobile is connected to the internet.

For full functionality, Red Sea's connected devices should be connected to the internet and your aquariums should be set to "Online". If you do not have an available Wi-Fi network at your Aquarium, set it as "Offline". You can change this setting later when Wi-Fi becomes available.

Make sure that you select the correct world time zone for where your aquarium is located. The default is the same time zone as your mobile which might be set for a different location. There is also a "Daylight saving Time" (DST) toggle that needs to be manually switched at the beginning and end of DST for your location.

If you have set up more than one aquarium, select the aquarium from the dropdown menu at the top of the screen before proceeding.

Set the controller to AP mode by pressing the settings button for 5 seconds (until double blink). The indicator LED should be blinking.

Tap the Add Device button from the Device Manager page, select the icon for the ReefATO+ and follow the instructions in the app. This may take a few seconds. If no devices appear on the list, check that the controller is in AP mode and/or refresh the page.

ReefBeat-App will now display a list of Wi-Fi networks and signal strengths that are available to the controller from its current location.

Select your preferred network and wait a few moments while the controller connects to it. The indicator LED will now be a solid red. Follow the instructions on the app for initial settings.

If you have set the aquarium to Offline, select the “Direct Mode” option at the top of the screen to skip the network connection. The indicator LED will continue to blink as the controller Wi-Fi remains in AP mode.

Follow the instructions in the app for connecting the controller to the ReefBeat App and cloud.

If you already have the pump, sensor and leak detector connected to the Controller follow the instructions in the App for setting them up.

Setting up the ReefATO+

ATO Auto-Fill

When setting up the system the App will ask for the length of tube used to connect the pump to the tube holder and the height from the bottom of the pump to outlet of the tube holder. These values can be modified later from: Homepage > ATO Settings > more settings, the length cannot be smaller than the height. These values are used to automatically set the appropriate pump speed for your installation and estimate the flow rate that will be used in the top-off log and reservoir volume monitor. The flow rate is only an approximation, if you want a more accurate record you can measure the actual flow rate for your system and update the App: Homepage > ATO Settings > more settings > Flow rate adjustment.

Each ATO level/temperature sensor has a 3-digit temperature calibration code (between 400 & 600) that needs to be entered to the App. The code can be found on a label attached to the sensor cable.

By default, the Auto-fill operation of the system is switched off to allow

you to ensure that the sensor is properly in place and that there is water in the reservoir before it is activated.

When you are ready, toggle the Auto-fill - ON.

ATO Reservoir Volume Monitor

The “Reservoir Volume Monitor” automatically deducts the amount of water used for each fill from the last updated reservoir volume that you entered. The ReefBeat will present the current volume in the reservoir and will let you know 24 hours before it is due to run out. Whenever you refill the reservoir, you will need to enter the new volume, so if you do not plan on maintaining this feature it is best not to enable it. The Monitor is only an approximate indication and has no effect on the operation of the auto-fill. The controller detects when the reservoir has actually run out of water by monitoring pump performance and will switch off the auto-fill until you refill the reservoir and “resume” it.

ATO Quick Action Return Delay

The ReefATO+ can be connected to the ReefBeat Maintenance/Emergency Quick-Action buttons. All devices that are configured for these Quick-Actions will immediately shut down when they are enabled and will resume immediately when they are switched off.

To delay the restart of the Auto-fill, set the Return Delay to the desired number of minutes required for all other equipment to restart and water levels in the sump to return to normal. Use this setting, for example, if you want to check the water level in the sump after a water change to allow the option to add some more salt water instead of having the ATO automatically add RO water.

Temperature monitor - Notification ranges

The ReefATO+ homepage presents the current temperature and a green/amber/red status indicator according to the desired and acceptable temperature ranges that you define for your system. If the temperature goes above or below the acceptable range you will get a notification to your mobile device. To set the temperature ranges: *Homepage > Temperature Settings > Temperature ranges*

Temperature monitor – Synchronize with another thermometer

The ReefBeat enables you to offset the presented temperature value to synchronize with another thermometer on your system. Note that most digital thermometers are accurate to ± 0.5 degrees. The ReefATO+ temperature can be restored to its default value at any time. After setting the new temperature use the “Current temperature” button to confirm that the temperature has updated correctly. *Homepage > Temperature Settings > Synchronize Temperature*

Leak Detector – Settings

The ReefBeat enables you to easily enable/disable the leak detector the audible buzzer alarm or connecting to the Emergency Quick-action of the aquarium. *Homepage > Leak Settings*

ATO and Temperature Logs

The Top-off log is a detailed record of number of fills and calculated volume of water that has been added to your aquarium for each day in the last 28 days (7 days if the aquarium is in offline mode), which can also be expanded to show the values per hour.

To view the log: *Homepage > ATO Settings > Top-off Log*

The Temperature log is a detailed record of minimum, maximum and

average temperatures recorded in your aquarium for each day in the last 28 days (7 days if the aquarium is in offline mode), which can also be expanded to show the values in 15-minute intervals throughout each day. To view the log: *Homepage > Temperature Settings > Temp Log*. If you plan on removing the sensor from the sump for a period of time you can avoid irrelevant temp readings from being recorded by temporarily disabling the log *Homepage > Temperature Settings > Update log*.

Export a copy of the logs by clicking “Send” at the top of the page and selecting your desired communication channel (Gmail, WhatsApp, FB messenger, etc.). You should do this on a regular basis if you wish to keep a record beyond the 28 days available from ReefBeat.

Operation

When the Auto-fill is enabled the ReefATO+ works independently unless it runs into an issue that needs your attention such as the following:

- Pump is missing, over-run timeout, running dry (empty reservoir) or blocked
- Level/temp sensor is missing
- Leak detector detects a leak

In all of the above cases, resolve the issue and resume the Auto-fill by either:

A short press on the manual pump button on the controller.

Pressing on the “resume” button in the App: *Homepage > ATO Settings > Resume button*.

Water changes or sump maintenance

Whenever you undertake any activity that will temporarily lower the water level in the sump and/or cause water near the leak detector, you should do one or more of the following to prevent the ReefATO+ from automatically “topping-off” or setting off the leak alarm.

- Switching off the “Auto-fill” from the ATO settings page will temporarily disable just this function
- Switching off the “Leak Detection” from the Leak settings page will temporarily disable this function
- Temperature - “Disable Log” will prevent irrelevant data from being recorded in the log

Switching OFF the ReefATO+ from the device manager will do all of the above at once

If using any of the above, remember to switch the function back on after maintenance is completed.

Connecting the ReefATO+ to the Maintenance shortcut will switch off all of the functions together with other ReefBeat devices that are in your sump.

When restarting after a water change it is recommended not to activate the Auto-fill immediately and to wait until all devices that affect the water level in the sump are fully operational. Use the “Check sump water level” option (Homepage > ATO Settings > More settings) to check that the water level is back to normal so that you can add/remove saltwater as required. If the water level is below the sensor you can manually add more water from the reservoir by pressing the button on the controller while periodically pressing the “GO” button to update the on-screen display of the water level.

ReefBeat Device Manager

The Device Manager is accessible from the Page menu in both the ReefBeat homepage and the device settings page, and contains a list of all the Red Sea connected devices that are installed on each aquarium.

The devices are listed according to type and in the order in which they were added to the aquarium. Tapping the 3-dot menu for the individual device opens a list of available actions for the specific device. Tapping the 3-dot menu for the device type opens a list of actions that can be done simultaneously for all devices of the same type.

Turn OFF / Turn ON

The device can temporarily be turned off/on without physically unplugging it or losing any of its settings.

For individual units: *Device manager > Device line menu > Turn OFF / ON.*

For device type: *Device manager > Device type menu > Turn OFF / ON*

Reconnecting a device to the ReefBeat Cloud

If you have received a disconnected notification for your device, it may need a reboot to reconnect it.

If the settings indicator LED on the device is ON click the Reboot button from the device manager: *Device Manager > Device Line menu > Reboot.*

If the settings indicator LED is OFF pressing the settings button on the device for less than 2 seconds will initiate the Reboot enabling the device to reconnect to the home network. If this does not resolve the issue, check that the network is available.

Firmware Updates

From time to time, you may receive a notification that a new firmware version is available for your device. It is important to keep your device firmware updated to ensure compatibility with updates to the ReefBeat App.

Individual units can be updated: *Device manager > Device line menu > Firmware Update.*

To update all units simultaneously: *Device manager > Device type menu > Firmware update*

Do not unplug a device while it is downloading and installing the new firmware.

Device Manager > Device Line menu > About - will show the currently installed firmware version. When the firmware update is complete, the "About" page will show the new version as the current version along with the date and time that the update was performed. All your previous settings will remain as before. If the firmware update is not successful, the device will automatically revert to the previous version. Repeat the process a few minutes later.

If your device does not seem to be performing correctly after the update, reboot the unit by pressing the settings button for less than 2 seconds.

Deleting a device

To remove a device from an aquarium, delete the unit from the ReefBeat App:

Device Manager > Device Line menu > Delete.

Deleting the device before it is switched off will prevent unnecessary notifications that it is disconnected from the cloud.

Clear settings

To permanently remove all user settings from the memory of the ReefMat and return it to its initial default state, perform the following steps.

If the device is connected to the ReefBeat, trigger the hard-reset option from the Device-Manager: *Device Manager> Device line menu > Hard-Reset*

If the device is not connected to the ReefBeat, press the Settings button for about 15 seconds (until the Wi-Fi indicator LED shows a double blink), release the button and wait for about 1 minute for the device to reboot.

The unit will restart without any user settings and with the Wi-Fi switched on, exactly as shipped from the factory. The unit will retain the latest installed version of the firmware.

Device Maintenance

Controller

For continued smooth running of the controller, we recommended making sure that it is kept clean, dry, and free of any buildup of salt deposits on a regular basis.

The unit is not waterproof. Do not submerge in water or other solutions.

ATO level/temperature sensor

Make sure that the sensor is kept free of any build-up of organic waste, algae growth, or salt deposits on a regular basis. The sensor is waterproof and can be safely washed under running water. The titanium tips can be brushed to remove any hard deposits.

It is recommended to wipe the sensor pins to remove build-up about once per month.

Switch off the Auto-fill before removing the sensor for maintenance.

If the sensor holder is not easily viewable, after returning the sensor use the “Check pump water level” to ensure that it is in the correct position.

Pump impellers

Remove the impellor chamber cover about once a month to ensure that the impellor chamber is free of any particulate matter. If necessary, the impellor can be removed for maintenance by inserting the point of a tweezer in the gap between the impellor and impellor shaft, rotate and pull outwards.

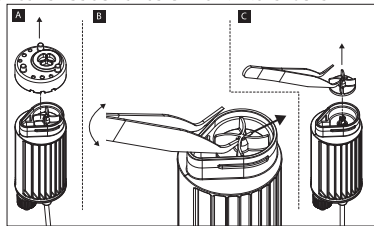

To replace the impellor, align the flat part of the impellor shaft with the impellor and push down until it clicks into position.

Leak Detector

Check the functionality of the leak detector about once per month by putting the pins in water. Make sure the pins are properly dry after the test and that you “resume” the Auto-fill.

Measuring actual pump flow rate

The actual flow rate of the pump is calculated by measuring the volume of water that is pumped in a known amount of time. Before starting, make sure that the App is set to the correct length and height of the silicone tube as these inputs affect the pump speed setting. Use a collection vessel with a volume of about 1 liter and run the pump for 15 seconds. Depending on the length of the tube, it may take a few seconds after starting the pump for the water to start flowing out the end of the tube. Start the pump running from the App and hold the end of the tube at approximately the same height as in normal operation. Once the water is flowing, collect water for 15 seconds and switch the pump off. In most setups the volume will be approximately 300 ml but could range from 75 to 750. Multiplying the volume by 4 will give the flow rate in ml/minute which should be entered in the App. Using a kitchen scale in grams and weighing the collection vessel before and after collecting the 15 second sample will give a more accurate result (1 g of water equals 1 ml). For increased accuracy, repeat about 3 times and use the average. The default estimated flow rate can be reinstated from the App at any time.

Troubleshooting

A full and up to date FAQ for the ReefATO+ and the ReefBeat app is available in the app (Homepage Main Menu> Help> FAQ) and on our website.

Q. I am having trouble installing the ReefBeat App or it crashes or does not seem to be working as described in the manual.

A. Check that your specific mobile device is on the list of supported devices on our website.

Q. My mobile is on the list of supported devices but keeps crashing.

A. Uninstall and reinstall the app and sign in again with your username and password. If this does not help, contact customer support.

Q. I'm having difficulty connecting the ReefATO+ to my home Wi-Fi network.

A. Check that the ReefATO+ Wi-Fi is working correctly by using the "Offline Direct Mode" option. If it does, try connecting to the hot-spot of a mobile phone in the same room: *Device Manager> Device Line menu> About > Connect.*

If neither of these options work, contact customer support. If they do work, the problem is likely with the router signal strength or its configuration, or it may be overloaded with devices.

- Check that the signal strength of your router is sufficient for a stable connection exactly where the ReefATO+ is located. You may need to install a suitable Wi-Fi extender closer to the aquarium.
- The router may have too many devices already connected to it.
- Your router may be configured not to allow devices like the ReefATO+ to be connected. This situation is common in an office environment, contact your IT professional.

Q. I keep getting notifications that my ReefATO+ is not connected.

A. If your network router is not permanently connected to the internet, set your Aquarium as "Offline" *My Aquariums> Device Line Menu>Offline.* If your network router is meant to be permanently connected, check the quality of the Wi-Fi connection between the ReefATO+ and your router or the stability of your internet connection.

Warranty

Red Sea Products Limited Warranty.

Thank you for purchasing a Red Sea REEFERE DC-Skimmer upgrade kit (hereinafter “the Product”).

Red Sea Aquatics (UK) Ltd. (hereinafter “Red Sea”) warrants the Product against manufacturer’s defects in material and workmanship for 2 years from your date of purchase.

Pump impellers are a wear item and as such Red Sea warrants the impellers against manufacturer’s defects in material and workmanship for 6 months from your date of purchase.

The warranty provided by Red Sea is NOT TRANSFERABLE AND IS LIMITED TO THE ORIGINAL PURCHASER. If the Product is eligible under this warranty, Red Sea will either repair the Product free of charge (not including shipping costs) with new or refurbished parts or replace the Product with a new or refurbished Product at Red Sea’s sole discretion.

This warranty DOES NOT COVER normal wear and tear. It also DOES NOT COVER damage which occurs in shipment and/or failures or defects resulting from use outside the normal, and/or natural disasters, accidents, power line surges, neglect, improper installation, operation or maintenance, servicing of the Product conducted by anyone other than an authorized Red Sea service center, or failure to use or assemble the Product in accordance with any instructions provided (in the Product manual or otherwise) or the technical and/or safety standards of the country in which the Product is used. Additionally, any modification of the Product other than by an authorized Red Sea service center will invalidate this warranty.

In order to affect this warranty, please contact your local service center. For your convenience, details of authorized service centers can be found on Red Sea’s website. Proof of purchase will be required before warranty performance is rendered.

The sole and exclusive remedy against Red Sea shall be for the repair or replacement of the Product as provided above. NO OTHER REMEDY (including but not limited to, incidental or consequential damages for lost profits, lost sales, or any other incidental or consequential loss) shall be available. Some jurisdictions do not allow the exclusion of incidental or consequential damage, so the above limitation may not apply to you. To the full extent allowed by applicable law, in no event shall Red Sea be liable for any loss or damage to aquatic life, and/or damage to other property and/or individuals resulting from the use of the Product or arising out of any breach of this warranty. All implied warranties are excluded to the full extent allowed by applicable law, and to the extent that they may not be excluded, are limited to the applicable warranty period set forth above. Some jurisdictions do not allow limitations on how long an implied warranty or condition lasts, so this limitation may not apply to you. The express warranties made in this warranty are exclusive and may not be altered, enlarged, or changed by any distributor, dealer, or other person, whatsoever.

USA

Some states do not allow the exclusion or limitation of incidental or consequential damages, or limitations on how long an implied warranty lasts, so the above exclusion or limitations may not apply.

CE Declaration of Conformity:

The equipment complies with the RF Exposure Requirement 2014/53/EU, Council Recommendation on the limitation of exposure of the general public to electromagnetic fields (0-300 GHz). This equipment meets the following conformance standards:

EN 300 328, EN 301 489-17.



DISPOSAL: Do not dispose this product as unsorted municipal waste. Collection of such waste separately for special treatment is necessary. This product must not be disposed together with the domestic waste. This product must be disposed at an authorized place for recycling of electrical and electronic appliances. By collecting and recycling waste, you help save natural resources, and make sure the product is disposed in an environmentally friendly and healthy way.

Red Sea U.S.A

4687 World Houston Parkway
#200 Houston,
TX 77032, U.S.A
support.usa@redseafish.com

Red Sea Europe

655 Rue des Frères
Lumière 27130 Verneuil
d'Avre et d'Iton, France
support.fr@redseafish.com

UK & Ireland

Red Sea Aquatics (UK) Ltd
PO Box 1237
Cheddar, BS279AG
uk.info@redseafish.com

Germany & Austria

Red Sea Deutschland
Büro Deutschland
Prinzenallee 7 (Prinzenpark)
40549 Düsseldorf
support.de@redseafish.com

China

Red Sea Aquatics (GZ) Ltd
Block 2-4, No.168, West Yingbin
Road, Xinhua Industrial Park,
Huadu District, Guangzhou City,
China, Postal code 510812.
Tel: +86-020-6625 3828
info.china@redseafish.com

株式会社エムエムシー企画レッ
ドシー事業部

〒174-0063
東京都板橋区前野町6-29-4
info@mmclanning.com